

PD685

Intrinsically Safe, NEMA 4, IP67 Loop-Powered Meter



Intrinsically Safe

3½ DIGITS • LARGE DISPLAY

- NEMA 4, IP67 Loop-Powered Field-Mount Process Meter
- 4-20 mA Input
- 1.1" (28 mm) 3½ Digits LCD Display; -1999 to 1999
- 1 V Drop (4 V Drop with Backlight)
- HART® Protocol Transparent
- Loop-Powered Backlight Standard
- Operates from -40 to 75°C (-40 to 167°F)
- Coarse and Fine Zero & Span Potentiometer Adjustments for Easy Field Scaling
- Plastic NEMA 4, IP67 Enclosure
- ATEX and IECEx Certified as Intrinsically Safe
- CE Marked
- Conformal Coated PCBs for Dust and Humidity Protection
- One ½" Conduit Hole (Rear, Top, Bottom or None)
- Pipe & Panel Mounting Kits
- Stainless Steel Tag Available

PD685 Intrinsically Safe, NEMA 4, IP67 Loop-Powered Meter

OVERVIEW

The PD685 is an ATEX and IECEx intrinsically safe, NEMA 4, IP67 loop-powered indicator that is easy to install and program. It can be seen from considerable distance in bright sunlight or dimly lit areas when the standard backlight feature is activated. The fact that this meter is loop-powered means that there is no need to run additional, costly power lines into a hazardous area. The meter gets all of the power it needs from the 4-20 mA loop and its 1 V (4 V with backlight) drop results in a minimal burden on the loop. The meter features a wide -40 to +75°C operating temperature range and is available with a ½" conduit hole in a location of your choice for easy installation. Calibration is a quick two-step process involving the adjustment of only two sets of coarse and fine, non-interacting potentiometers.

SPECIFICATIONS

Except where noted all specifications apply to operation at +25°C.

Input: 4-20 mA @ 30 VDC maximum

Display: 1.1" (28 mm) LCD, 3½ digits; -1999 to +1999

Backlight: Powered by 4-20 mA loop. Intensity varies with signal level

Accuracy: ±0.1% FS ±1 count

Approvals: ATEX and IECEx Certified as intrinsically safe with entity, for use in Equipment Group II, categories 1G (for Gas) and 1D (for Dust), suitable for Zone 0, 1 & 2 (for Gas) and Zone 20, 21 & 22 (for Dust) classified areas, and carrying the following markings: II 1 GD. Ex ia IIC T4 Ga. Ex ia IIIC T135°C Da. -40°C ≤ Ta ≤ +75°C.

Entity Parameters: Ui = 30 V, Ii = 175 mA, Pi = 1 W, Ci = 0, Li = 0

Decimal Point: User selectable via J2 jumper

Calibration: 4-step coarse & fine control; non-interacting zero & span

Calibration Range: 4 mA input: -1000 to +1000;

20 mA input: between 20 and 2000 counts > 4 mA display

Display Update Rate: 2.5/second

Maximum Input Current: 30 mA

Input Overload Protection: Over voltage protection to 30 V max (between S+ and S-)

Maximum Voltage Drop: 1 V @ 20 mA (4 V @ 20 mA with backlight)

Operating Temperature: -40 to +75°C

Storage Temperature: -40 to +85°C

Relative Humidity: 0 to 90% non-condensing. Printed circuit boards are conformally coated.

Enclosure: Impact-resistant, glass-filled, polycarbonate body, opaque; Impact-resistant, polycarbonate cover, transparent; Polyurethane/polymer gasket; Polyamide/plastic cover screws; NEMA 4, IP67

Connections: Removable screw terminal block, 12 to 24 AWG.

Conduit Hole: One ½" conduit hole may be provided; refer to Ordering Information to specify hole location; request model (-Z) for no conduit hole.

Weight: 12 oz (340 g)

Warranty: 2 years parts & labor

COMPLIANCE INFORMATION

Product Markings:

CE 0518 Ex II 1 GD Ex ia IIC T4 Ga
Ex ia IIIC T135°C Da
-40°C ≤ Ta ≤ +75°C; IP67

Special Conditions for Safe Use:

1. The permitted ambient temperature range for the PD685 is -40 to +75°C (-40 to 167°F).
2. Use suitably certified and dimensioned cable entry device and/or plug. The equipment shall be installed such that the supply cable is protected from mechanical damage. The cable shall not be subjected to tension or torque.
3. Under certain extreme circumstances, the non-metallic parts incorporated in the enclosure of this equipment may generate an ignition-capable level of electrostatic charge. Therefore, the equipment shall not be installed in a location where the external conditions are conducive to the build-up of electrostatic charge on such surfaces. This is particularly important if the equipment is installed in a zone 0 location. In addition, the equipment shall only be cleaned with a damp cloth.
4. The cable entry into the enclosure shall be by means of conduit or cable gland and shall provide a minimum degree of protection of IP5X.

Year of Construction: This information is contained within the serial number with the first four digits representing the year and month in the YYMM format.

For European Community: The PD685 must be installed in accordance with the Essential Health & Safety Requirements of Directive 2014/34/EU, the product certificates CML 17ATEX2113X and IECEx CML 17.0052X, and the product manual.

All controls and wiring connectors are accessed by opening the enclosure. To access electrical connectors, remove the enclosure cover, unscrew the two captive screws that fasten the printed circuit board, and remove the printed circuit board from the enclosure.

NOTE 1: If any of the following operations are performed in the hazardous area, all appropriate hazardous area procedures must be followed.

NOTE 2: To prevent damage to electronic components caused by electrostatic discharge, a grounding strap should be worn when servicing the display.

Conduit Installation Instructions

1. Remove the printed circuit board from the enclosure.
2. Connect appropriate size conduit fittings to the hole provided. For enclosures without a pre-drilled hole, the installer must make a hole in accordance with the instructions for the particular conduit fitting being installed.
3. Connect conduit (with attached hubs) to the enclosure. Conduit hubs must be connected to the conduit prior to being connected to the enclosure. Use only conduit hubs that are designed to maintain NEMA 4 or IP67 ratings.

Note: Please read PD685 Intrinsic Safety Control Drawing (LIM685-2) for more information pertaining to the conduit holes.

Mounting Instructions

1. Remove the enclosure cover from the base.
2. Insert mounting hardware into mounting holes in enclosure base (see Figure 7).
3. Secure the enclosure base to the mounting surface using the inserted hardware.
4. Re-attach the enclosure cover to the base.

SETUP

The only tools needed for calibration are a calibrated current source and a small slotted/flathead screwdriver.

Calibration Connections

To access the input terminals it is necessary to remove the enclosure cover and the printed circuit board. This is done by loosening the four screws on the enclosure cover and removing the cover. Completely loosen both thumb screws that hold the printed circuit board to the enclosure. Turn it over to gain access to the reverse side. Then, proceed to connect a calibrated current source per Figure 1.

Safety Information

1. Read complete instructions prior to installation and operation of the meter.
2. Installation and service should be performed only by trained service personnel.
3. Service requiring replacement of internal components must be performed at the factory.
4. Control room equipment must not use or generate more than 250 VRMS or VDC.
5. Hazardous location installation instructions for associated apparatus (barrier) must be followed when installing this equipment.
6. For safe installation of an ATEX approved transmitter in series with PD685 loop indicator, the hazardous location installation instructions for the transmitter, PD685 loop indicator, and associated apparatus (barrier) must be compatible.
7. PD685 indicator does not add capacitance or inductance to loop under normal or fault conditions.
8. Substitution of components may impair hazardous location safety.
9. Equipment contains non-metallic materials and therefore special care and consideration should be made to the performance of these materials with respect to chemicals which may be present in a hazardous environment.

Decimal Point Selection

The decimal point jumper array J2 is located in the lower right corner of the printed circuit board next to the display. It is labeled DDD.D, DD.DD, and D.DDD. Place a jumper over both pins of DDD.D for a display of 199.9, DD.DD for 19.99, or D.DDD for 1.999.

Calibration

LO and HI coarse and fine calibration controls are located below the display (see Figure 2). The meter is factory calibrated to display -500 at 4 mA and 1500 at 20 mA. Use the HI and LO COARSE controls for large range changes during calibration and the HI and LO FINE controls for precision changes. Apply a 4 mA signal and adjust the LO controls to display the desired reading. Apply a signal between 16 and 20 mA and adjust the HI controls to display the desired reading. Complete the calibration procedure by making minor adjustments to the LO and HI controls as necessary.

CONNECTIONS

Field wiring is made to the back side of the printed circuit board which is mounted in the enclosure.

- S+** Signal Positive Connection
- S-** Signal Negative Connection
- B-** Signal Negative Connection (if using Backlight)

Figure 1: Calibrator Connection

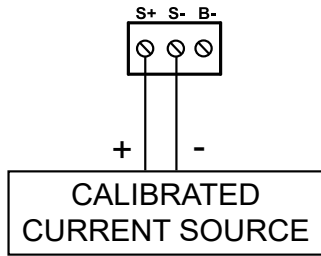

Figure 2: Calibration Controls Location

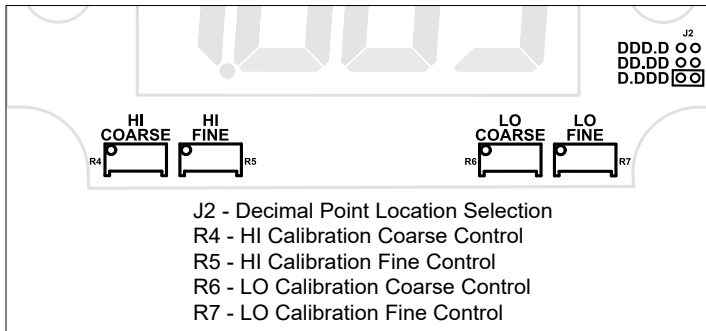
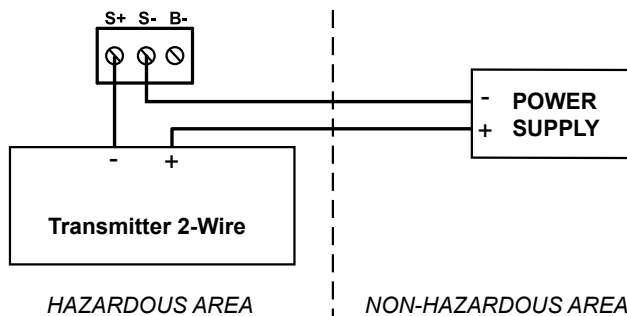

Figure 3: Control Loop Connections (2-Wire)



Installation

Installation of the meter involves removing the printed circuit board from its enclosure and connecting a 1/2" conduit fitting to the hole provided. Refer to PD685 ATEX and IECEx Certified Loop-Powered Meter Intrinsic Safety Control Drawing diagrams (LIM685-2) for further details. Wall mounting holes are located in each corner of the enclosure (see Figure 7).

Loop Connections

Disconnect power to the loop and wire the meter as illustrated in (Figures 3 & 4) for 2-wire transmitter configuration, (Figures 5 & 6) for 4-wire transmitter configurations, and the PD685 ATEX and IECEx Certified Loop-Powered Meter Intrinsic Safety Control Drawing diagrams (LIM685-2) supplied with the instrument. Connect the loop return wire to S- to disable the backlight feature or connect it to B- to enable the backlight feature.



Warning: Electrostatic hazard. Clean only with a moist cloth. Protect enclosure from exposure to chemical solvents and excessive ultraviolet (UV) light (e.g. sunlight).

Figure 4: Control Loop Connections with Backlight (2-Wire)

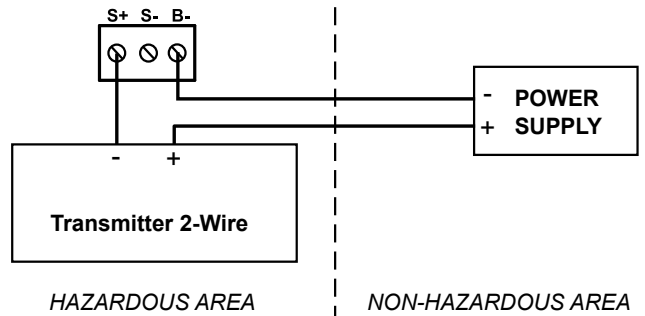

Figure 5: Control Loop Connections (4-Wire)

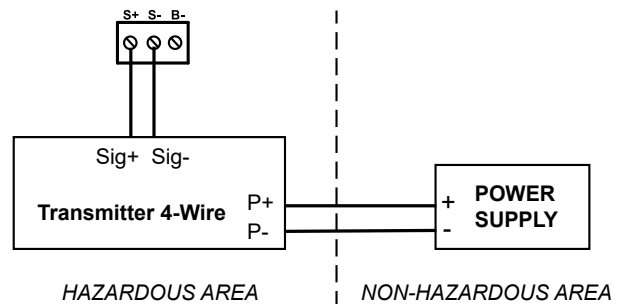
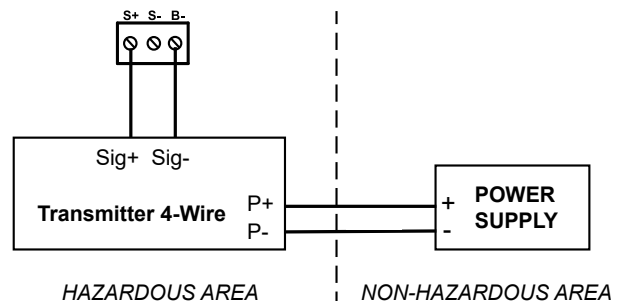

Figure 6: Control Loop Connections with Backlight (4-Wire)



PD685 Intrinsically Safe, NEMA 4, IP67 Loop-Powered Meter

DIMENSIONS

Figure 7: Dimensions and Wall Mounting Information

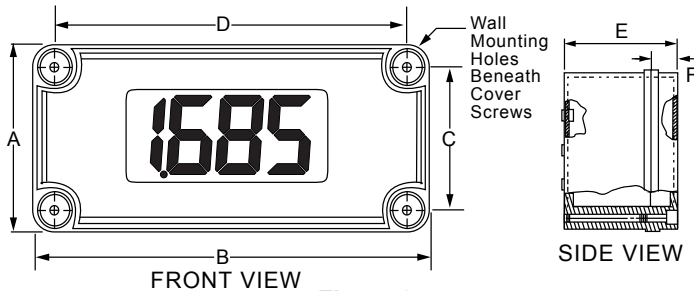

A: 3.15" (80 mm) C: 2.44" (62 mm) E: 2.75" (70 mm)
 B: 5.12" (130 mm) D: 4.41" (112 mm) F: 0.79" (20 mm)

MOUNTING

Pipe Mounting Kit

The PDA6845 is a pipe mounting kit with two mounting holes. It provides all of the necessary hardware to mount the PD685 to a 2" pipe. It is available in zinc plated and stainless steel materials.

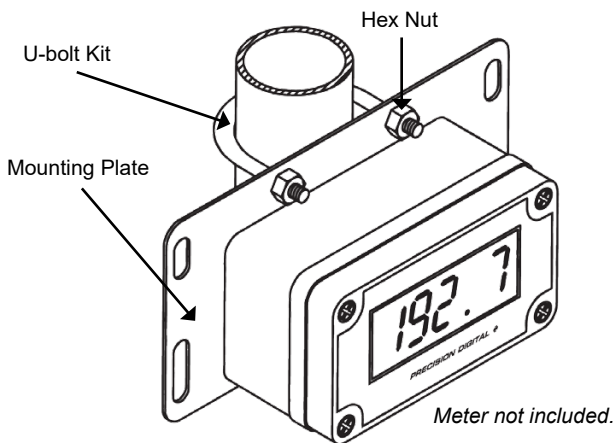

Panel Mounting Kit

The PDA6854 is a panel mounting kit for the PD685. It provides all of the necessary hardware to mount the PD685 meter to an equipment panel. This panel mounting kit is not intended to provide waterproof protection to the panel.

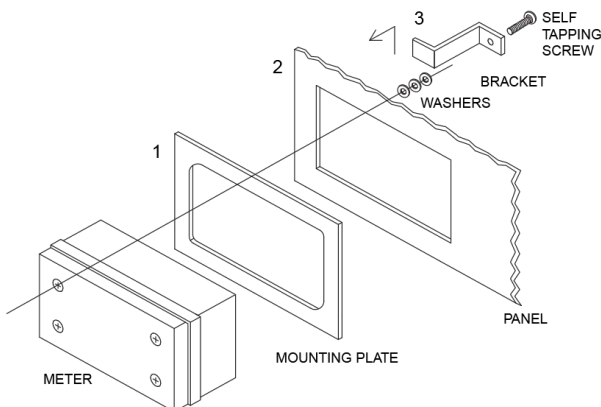

ORDERING INFORMATION

PD685 I.S. NEMA 4, IP67 Loop-Powered Meter		
Model	Description	Conduit Hole Location for 1/2" Fitting
PD685	ATEX & IECEx Certified Intrinsically Safe NEMA 4, IP67 Meter with Conduit Hole Location in Bottom of Enclosure	Bottom
PD685-X	ATEX & IECEx Certified Intrinsically Safe NEMA 4, IP67 Meter with Conduit Hole Location in Rear of Enclosure	Rear
PD685-Y	ATEX & IECEx Certified Intrinsically Safe NEMA 4, IP67 Meter with Conduit Hole Location in Top of Enclosure	Top
PD685-Z	ATEX & IECEx Certified Intrinsically Safe NEMA 4, IP67 Meter with no Conduit Hole	None

Accessories	
Model	Description
PDA6854	Panel Mount Kit (does not provide IP67 seal to panel)
PDA6845	2" Pipe Mounting Kit (zinc plated steel)
PDA6845-SS	2" Pipe Mounting Kit (stainless steel)
PDA-SSTAG	Stainless Steel Tag

Stainless Steel Tags

Laser Etched • Up To 46 Characters • Lead Seal & Wire



BUY NOW AT
www.predig.com/pda-sstag

Your Local Distributor is:

Disclaimer

The information contained in this document is subject to change without notice. Precision Digital Corporation makes no representations or warranties with respect to the contents hereof, and specifically disclaims any implied warranties of merchantability or fitness for a particular purpose. ©2018 Precision Digital Corporation. All rights reserved.

LIM685_G 10/18



EU DECLARATION OF CONFORMITY

Issued in accordance with ISO/IEC 17050-1:2004 and ATEX Directive 2014/34/EU.

We,

Precision Digital Corporation
233 South Street
Hopkinton, MA 01748 USA

as the manufacturer, declare under our sole responsibility that the product(s),

Model PD685 Loop Powered Meter

to which this declaration relates, is in conformity with the European Union Directives shown below:

2014/35/EU	Low Voltage Directive
2014/34/EU	ATEX Directive
2014/30/EU	EMC Directive
2011/65/EU	RoHS Directive

This conformity is based on compliance with the application of harmonized or applicable technical standards and, when applicable or required, a European Union notified body certification.

Standards:

EN 55011:2016
EN 60079-0:2012+A11:2013
EN 60079-11:2012
EN 61010-1:2010
EN 61326-1:2013

EC Type Examination Certificate: CML 17ATEX2113X

Product Markings:

 II 1 GD
Ex ia IIC T4 Ga
Ex ia IIIC T135°C
Tamb = -40°C to +75°C

ATEX Notified Body for EC Type Examination Certificate: Certification Management Limited, NB 2503
Unit 1 Newport Business Park, New Port Road,
Ellesmere Port CH65 4LZ, UK

ATEX Quality Assurance Notification No.: SIRA 10 ATEX M462

ATEX Notified Body for Quality Assurance: Sira Certification Service, NB 0518
Unit 6, Hawarden Industrial Park
Hawarden, Deeside, CH5 3US, UK

Signed for and on behalf of Precision Digital Corporation:

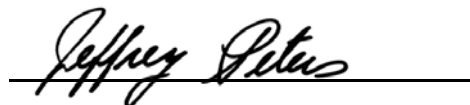

Name: Jeffrey Peters
Company: Precision Digital Corporation
Title: President
Date: 02/12/2018

Document No: DoC PD685 {021218}